



Series  
DSX

SIZE 5 COAXIAL SOCKET CONTACT  
FOR RG179 AND RG187 CABLES  
CUSTOMER : AMD

Issue:  
13 APRIL 99

Page  
1 / 1

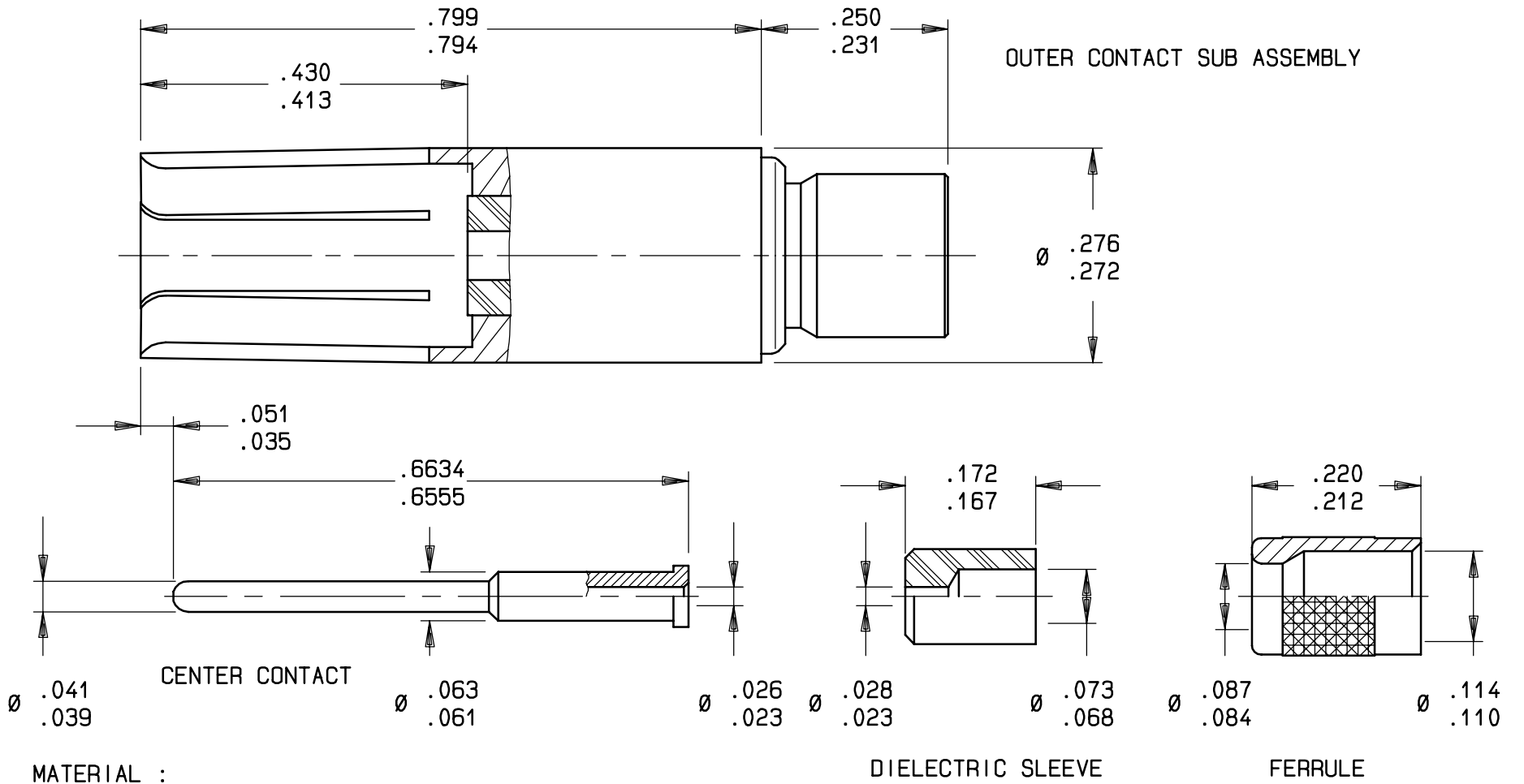

**MATERIAL :**  
 OUTER CONTACT : BERYLLIUM COPPER  
 INSULATOR : PTFE  
 CENTER CONTACT : BRASS  
 FERRULE : BRASS  
**FINISH (ALL METAL PARTS)**  
 GOLD PLATE PER MIL-G-45204 : 50 MICROINCHES OVER NICKEL

**WIRING INSTRUCTIONS:**

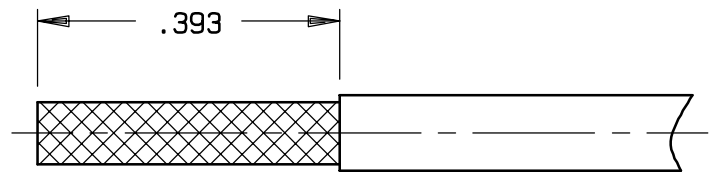

STRIP THE BRAID AT DIMENSION SHOWN

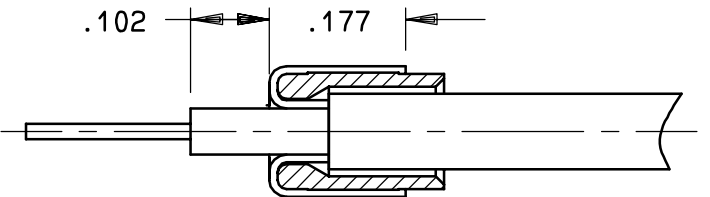

SLIDE THE FERRULE OVER THE BRAID UNTILL IT BUTTS AGAINST CABLE JACKET  
 FOLD BACK BRAID OVER FERRULE  
 CUT BRAIDS AT DIMENSION SHOWN  
 STRIP CENTER CONDUCTOR AT DIMENSION SHOWN

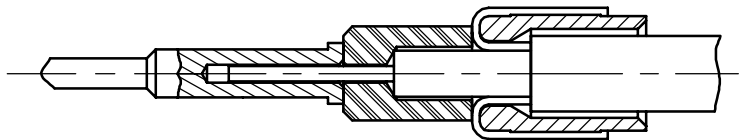

SLIDE DIELECTRIC SLEEVE AND CENTER CONTACT OVER CENTER CONDUCTOR  
 CRIMP CENTER CONTACT USING :  
 CRIMPING TOOL : M22520/2-01 RADIAL 282281  
 SELECTOR : 6  
 POSITIONER : K345 RADIAL 282550

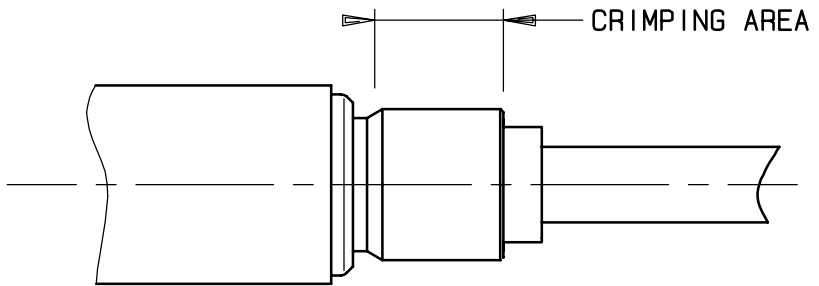

INTRODUCE CENTER CONTACT SUB ASSEMBLY INTO OUTER CONTACT AND CRIMP USING:  
 CRIMPING TOOL : M22520/5-01 RADIAL 282293  
 DIE : M22520/5-05 RADIAL 282246 HEX B 4,5/FLATS

This information is given as an indication. In the continual goal to improve our products, we reserve the right to make any modifications judged necessary.

CREATION	.	.	.	.
PEN: /	.	.	.	.
NOM: MACARI	.	.	.	.
DATE: 09/06/82	.	.	.	.
APPR.: .	13/04/99	ENGLISH CREATION	GOMBERT	.
	Issue	Revisions	Name	Approved